

# INSTRUCTIONS D'ASSEMBLAGE

ATTACHE DE PELLE « CLICK N GO 2 »  
Polaris RZR 1000

KIMPEX N° 374402

## Pièces provenant de l'ensemble d'attache de pelle

Réf.	Description	Qté	Réf.	Description	Qté
01	Plaque d'attache	1	04	Boulon de carrosserie M8-1.25 x 45 mm	2
02	Espaceur	2	05	Écrou M8-1.25	2
03	Support avant	1			

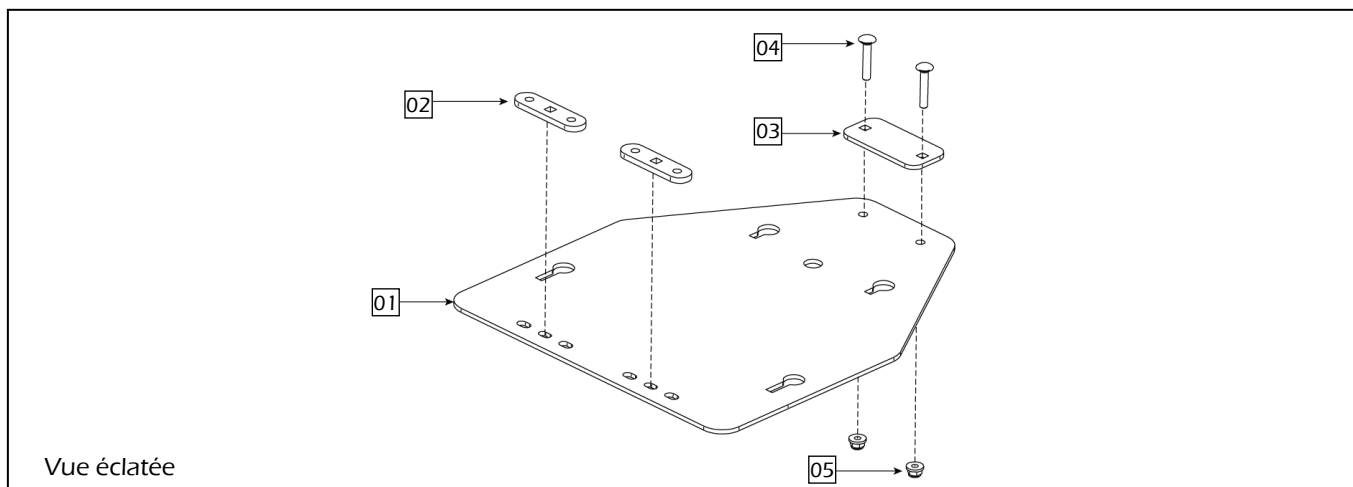

## Pièces provenant de l'ensemble du châssis-poussoir

Réf.	Description	Qté	Réf.	Description	Qté
A	Plaque en V	1	D	Écrou hex. M8-1.25	17
B	Boulon en U carré 92.9 mm	4	E	Boulon hex. M8-1.25 x 20 mm	1
C	Boulon de carrosserie M8-1.25 x 25 mm	8	F	Mèche 10 mm	1

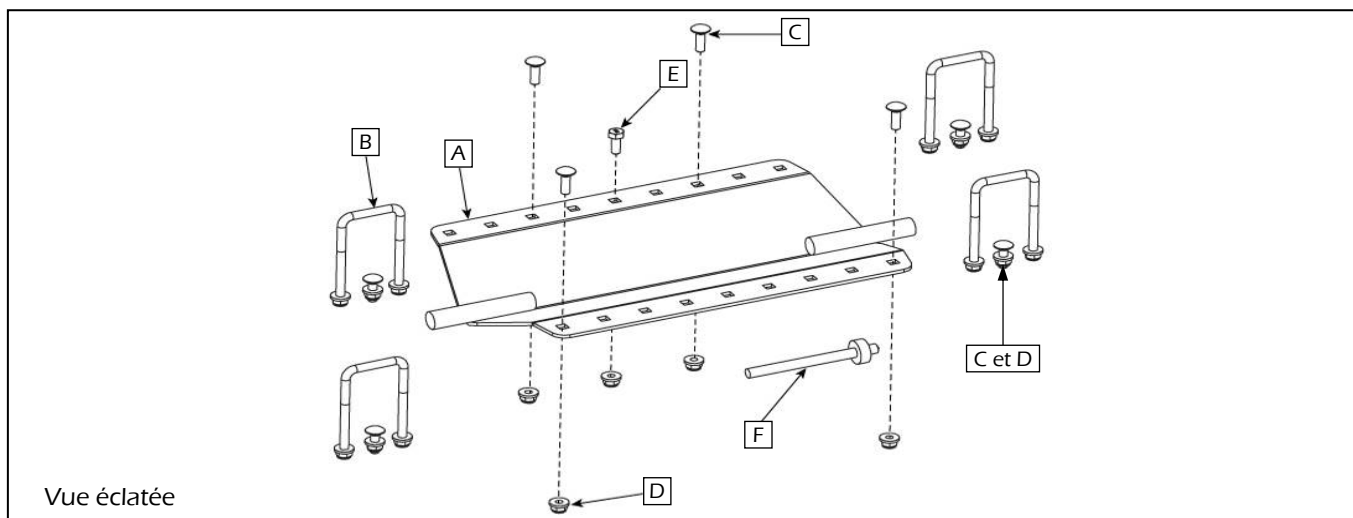

# INSTRUCTIONS D'ASSEMBLAGE

## ATTACHE DE PELLE « CLICK N GO 2 » Polaris RZR 1000

KIMPEX N° 374402

### Procédure d'installation de l'attache de pelle

- 1) Installez le support avant **03** ainsi que deux (2) boulons de carrosserie M8-1.25 x 45 mm **04**. Installez la plaque d'attache **01** sous le véhicule seulement à l'aide des deux (2) boulons **04** installés précédemment et des deux (2) écrous M8-1.25 **05** (cette étape sert seulement à percer les trous dans la plaque de protection du véhicule). Consultez les figures 1 et 2.

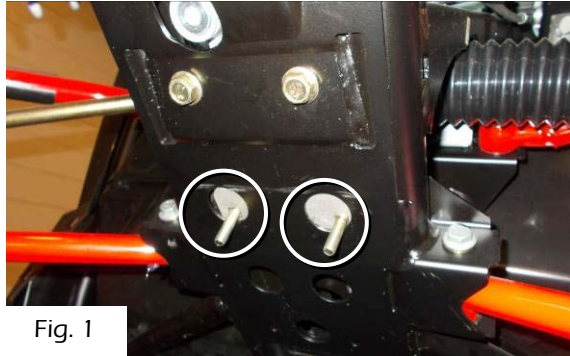

Fig. 1

- 2) En vous servant de la plaque comme guide, percez à l'aide de l'outil fourni aux endroits indiqués à la figure 2.

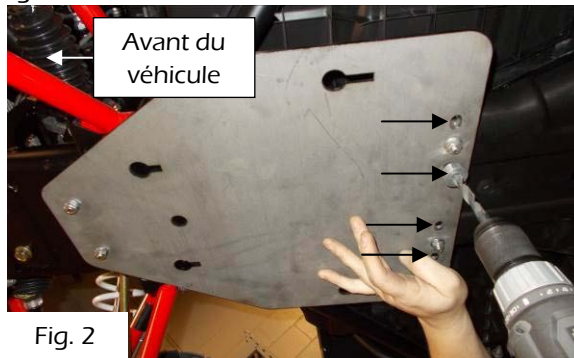

Fig. 2

- 3) Enlevez la plaque de protection du véhicule. Passez deux (2) boulons en U carrés 92.9 mm **B**. Consultez la figure 3.



Fig. 3

- 4) Retirez la plaque d'attache **01**.
- 5) Préassemblez les deux (2) espaceurs **02** avec deux (2) boulons de carrosserie M8-1.25 x 25 mm **C** et deux (2) écrous hex. M8-1.25 **D**. Serrez les premiers filets seulement. Consultez la figure 4.

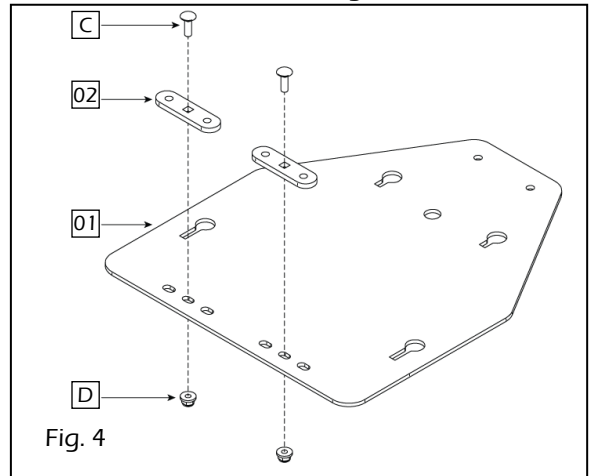

Fig. 4

- 6) Passez deux (2) boulons en U carrés 92.9 mm **B** dans le châssis du véhicule dans les trous préalablement percés. Consultez la figure 1 au besoin.
- 7) Installez le préassemblage de la plaque d'attache **01** et des deux (2) espaceurs **02** avec les boulons en U carrés 92.9 mm **B** installés à l'étape précédente. Fixez à l'aide de six (6) écrous hex. M8-1.25 **D**, puis serrez le tout. Consultez la figure 5.







Fig. 5



# INSTRUCTIONS D'ASSEMBLAGE

## ATTACHE DE PELLE « CLICK N GO 2 » Polaris RZR 1000

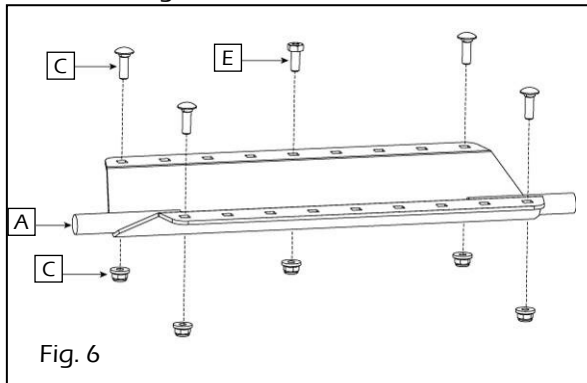

KIMPEX N° 374402

- 8) Assemblez quatre (4) boulons de carrosserie M8-1.25 x 25 mm  et un (1) boulon hex. M8-1.25 x 20 mm  sur la plaque en V  à l'aide de cinq (5) écrous hex. M8-1.25 . Vissez les premiers filets seulement, à l'exception du boulon hex. M8-1.25 x 20 mm  qui doit être complètement serré. Consultez la figure 6.

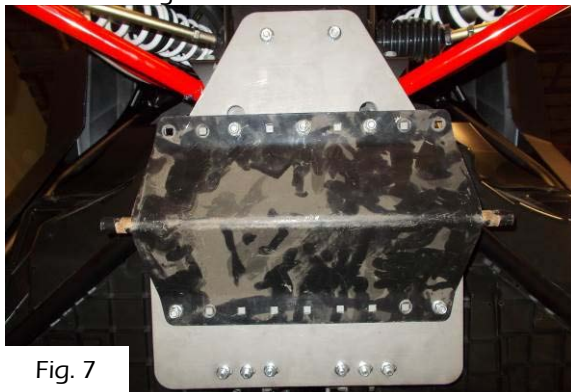

- 9) Assemblez la plaque en V  sur la plaque d'attache  en alignant d'abord les boulons de carrosserie arrière, puis les boulons de carrosserie avant . Consultez la figure 7.



- 10) Une fois les boulons de carrosserie M8-1.25 x 25 mm  sont glissés au fond des trous oblongs de la plaque d'attache , serrez tous les écrous en place.

### Position de l'assemblage du crochet du châssis-poussoir

Installez l'assemblage du crochet du châssis-poussoir dans la position 3. Référez-vous aux instructions du châssis-poussoir pour obtenir la procédure d'assemblage.



# ASSEMBLY INSTRUCTIONS

"CLICK N GO 2" PLOW ATTACHMENT  
Polaris RZR 1000

KIMPEX NO. **374402**

## Parts from the Plow Attachment Assembly

Ref.	Description	Qty	Ref.	Description	Qty
01	Attachment plate	1	04	M8-1.25 x 45 mm carriage bolt	2
02	Spacer	2	05	M8-1.25 nut	2
03	Front bracket	1			

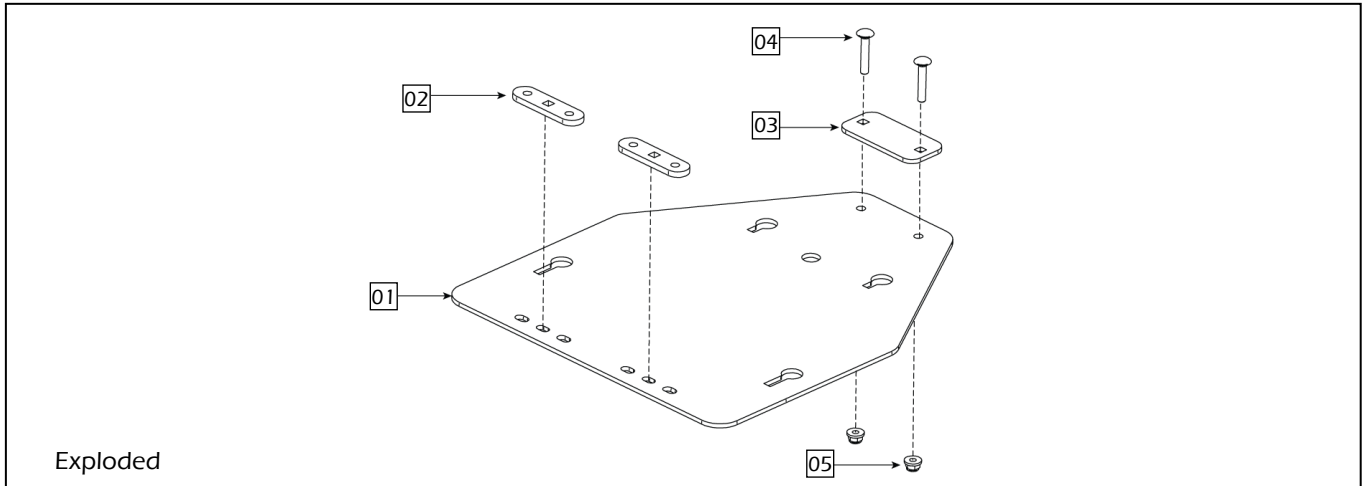

## Parts from the Push Frame Assembly

Ref.	Description	Qty	Ref.	Description	Qty
A	V-plate	1	D	M8-1.25 hex. nut	17
B	92.9 mm square bend U-bolt	4	E	M8-1.25 x 20 mm hex. bolt	1
C	M8-1.25 x 25 mm carriage bolt	8	F	10-mm drill bit	1

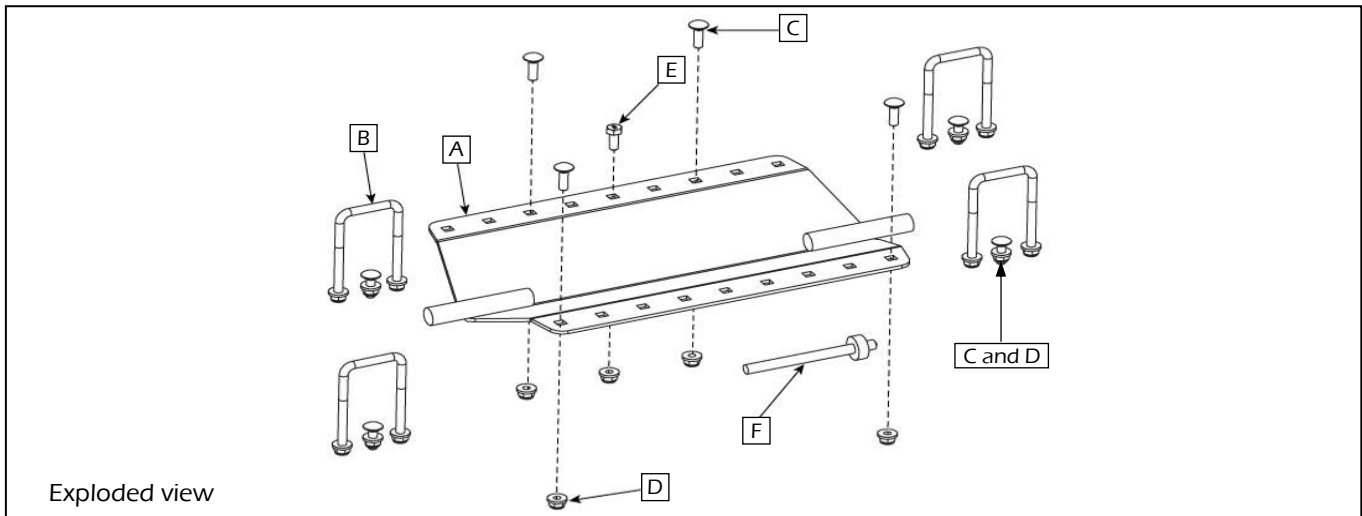



# ASSEMBLY INSTRUCTIONS

## "CLICK N GO 2" PLOW ATTACHMENT Polaris RZR 1000

KIMPEX NO. **374402**

### Plow Attachment Installation Procedure

- 1) Install the front bracket **03** and two (2) M8-1.25 x 45 mm carriage bolts **04**. Install the attachment plate **01** under the vehicle only using the two (2) bolts **04** installed previously and the two (2) M8-1.25 nuts **05** (this step is used only to drill holes in the skid plate of the vehicle). See Figures 1 and 2.

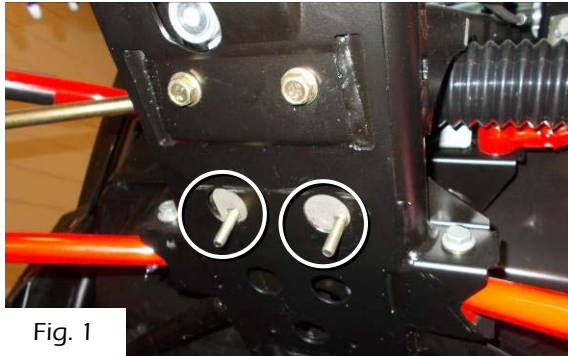

Fig. 1

- 2) Using the plate as a reference, drill with the tool provided at the locations identified in Figure 2.

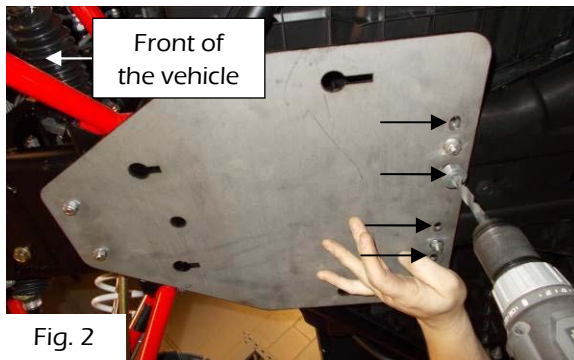

Fig. 2

- 3) Remove the skid plate from the vehicle. Pass two (2) 92.9 mm square bend U-bolts **B**. See Figure 3.



Fig. 3

- 4) Remove the attachment plate **01**.
- 5) Pre-assemble the two (2) spacers **02** with two (2) M8-1.25 x 25 mm carriage bolts **C** and two (2) M8-1.25 hex. nuts **D**. Tighten the first threads only. See Figure 4.

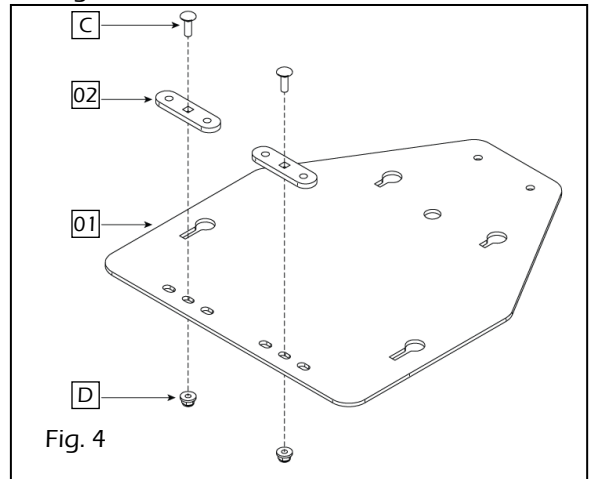

Fig. 4

- 6) Pass two (2) 92.9 mm square bend U-bolts **B** in the vehicle frame in holes previously drilled. See Figure 1 if needed.
- 7) Install the pre-assembly of the attachment plate **01** and two (2) spacers **02** with the 92.9 mm square bend U-bolts **B** installed in the previous step. Secure with six (6) M8-1.25 hex. nuts **D**, then tighten all U-bolts and nuts. See Figure 5.

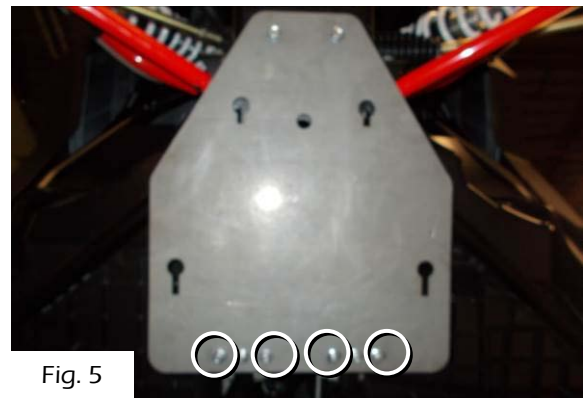







Fig. 5



# ASSEMBLY INSTRUCTIONS

## "CLICK N GO 2" PLOW ATTACHMENT Polaris RZR 1000

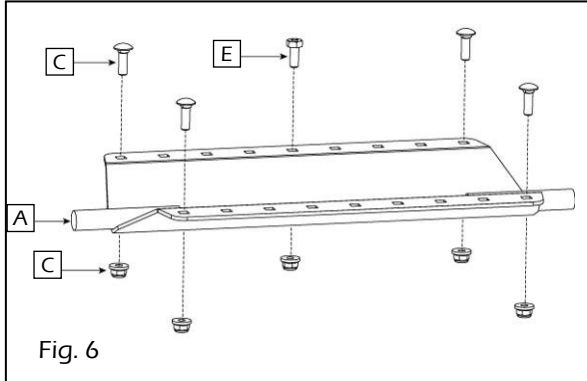

KIMPEX NO. **374402**

- 8) Assemble four (4) M8-1.25 x 25 mm carriage bolts  and one (1) M8-1.25 x 20 mm hex. bolt  on the V-plate  using five (5) M8-1.25 hex. nuts . Screw the first threads only, except the M8-1.25 x 20 mm hex. bolt  which must be fully tightened. See Figure 6.



- 9) Assemble the V-plate  on the attachment plate  by first aligning the rear carriage bolts, then the front carriage bolts . See Figure 7.



- 10) Once the M8-1.25 x 25 mm carriage bolts  are inserted to the bottom of the oblong holes of the attachment plate , tighten all bolts in place.

### Position of the Push Frame Hook Assembly

Install the push frame hook assembly in Position 3. Refer to the instructions of the push frame for the assembly procedure.